



IN-FIELDER

INFIELDER

**REIST
INDUSTRIES**

MANUFACTURED IN CANADA



BE DIAMOND READY

RECLAIM, RECONDITION, AND REDEFINE YOUR DIAMOND — ALL IN A SINGLE PASS.

The Reist In-Fielder is a precision-engineered grooming system built with six integrated conditioning stages, designed to transform hard, uneven infields into smooth, level playing surfaces. Whether you're resurfacing compacted material or delivering a final finish, each stage works in harmony to restore your baseball diamond with professional-grade results.

Designed for simplicity without compromising performance, the In-Fielder is simple and easy to operate. With just two intuitive adjustments — the grader blade depth and brush height — any operator can achieve consistent, high-quality outcomes with ease. From schools to stadiums, the Reist In-Fielder makes expert-level field conditioning accessible to all.



IN-FIELDER D72



IN-FIELDER D60



IN-FIELDER D84

TRUSTING THE PROCESS



1

SERRATED CUTTING EDGE

- Fills in any high or low spots

2

BASKET ROLLER

- Crushes any existing course or clumpy material

3

LEVELING BAR

- Smooths out any high points

4

PACKER ROLLER

- Packs the surface

5

HARROW TINE RAKE (OPTIONAL)

- Cuts deep into the surface for better air flow

6

ADJUSTABLE GROOMING BRUSH

- Gives a manicured look

SPECIFICATIONS

In-Fielder	D60	D72	D84
Dimensions (WLH)	67X43X31"	80 X 48 X 32"	97 X 46 X 33"
Width	60"	72"	84"
Hitch	CAT I	CAT I	CAT I & II
Weight (lbs)	620	835	935
Pulverizer Roller	5"	5"	5"
Packer Roller	1 PC. STEEL ROLL	6" X 12" UHMW ROLLS	6" X 12" UHMW ROLLS

Model Specific Options	Part Number	Part Number	Part Number
Rear Long Tine Rake Attachment	RLTR-60	RLTR-H-72	N/A
Rear Long Tine Rake Hydraulic	N/A	N/A	RLTR-84

FEATURES



GRADER BLADE

The heavy duty bolt-on serrated grader blade is fixed to the front of the unit. It cuts across the surface removing the high spots and filling in the lower ones.



ADJUSTABLE REAR BRUSH (VARIES BY MODEL)

Sweeps across the surface distributing loose material and providing a smooth consistent playing surface.



BASKET ROLLER

The floating basket roller breaks up any existing course or clumpy material, to provide consistent material density.



PACKER ROLLER (VARIES BY MODEL)

With all the weight on the roller, it stabilizes the Infielder and packs the surface. The D60 has a single-piece steel roller, while the D72 and D84 have 12" UHMW sectional rollers to prevent skidding when turning.





TOW KIT WITH WHEELS (D60 & D72)

- Tow kit for D60 & D72

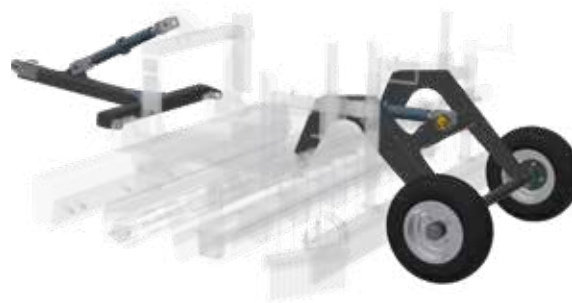

TOW KIT EXTENDED (D72)

- Tow kit for D72 In-Fielder with long tine harrow option



ROTARY SWEEPER (ALL MODELS)

- 20" diameter nylon bristle brush with spring loaded break-away arm
- Hydraulic-driven
- Adjustable gauge wheel
- Sweep material off grass and away from fence
- Prevent out field ridge



WATER TANK (ALL MODELS)

- 50 gallon capacity
- 12V pump and rear nozzle



HAND WAND KIT

- Hand wand kit for spraying water on the pitcher's mound



FRONT NOZZLE KIT

- For dust suppression
- Front nozzle, switch and pump

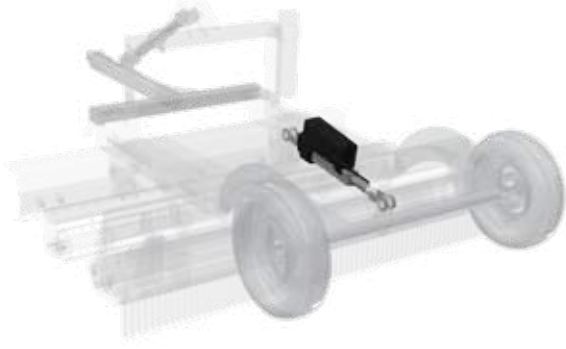

ELECTRIC ACTUATOR

- 100mm Stroke

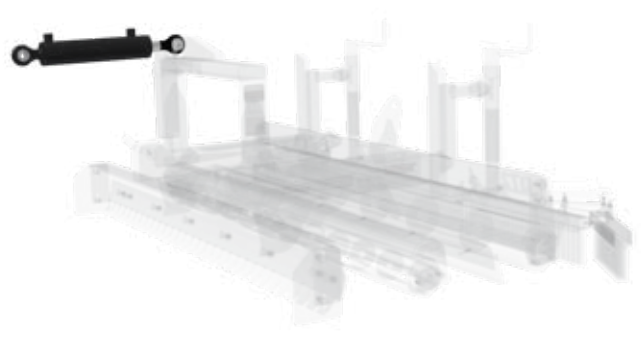

HYDRAULIC TOP LINK (CAT I & II)

- Available for CAT I & CAT II
- Available in 8", 10" and 14" stroke lengths



REAR LONG TINE HARROW (D60)

- 14" long x $\frac{3}{8}$ " spring tines
- Loosen up hard-packed surfaces, which helps to dry the soil quicker

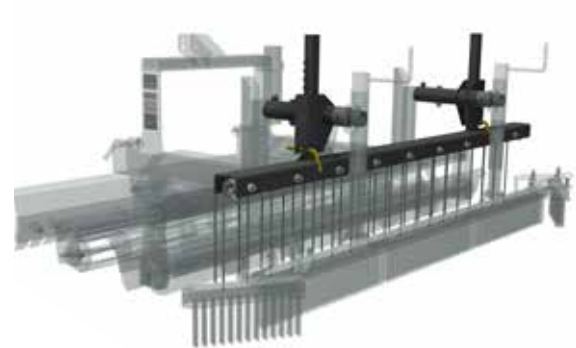

REAR LONG TINE HARROW (D72)

- 14" long x $\frac{3}{8}$ " spring tines
- Loosen up hard-packed surfaces, which helps to dry the soil quicker



REAR LONG TINE HARROW HYDRAULIC (D84)

- 14" long x $\frac{3}{8}$ " spring tines
- Loosen up hard-packed surfaces, which helps to dry the soil quicker



EDGER

- Get the perfect edge



SULKY

- Sulky fits between the UTV or ATV and the Infielder
- Required for UTVs or ATVs where the hitch moves with the suspension, or is unstable because of low psi tires
- Keeps the Infielder level
- Sulky fits into a 2" receiver
- 21" wide x 20" long x 16" high
- 45 lbs. weight





SEE THE
IN-FIELDER
IN ACTION

reistindustries.com



Reist Industries

100 Union Street
Elmira, Ontario, Canada
N3B 3L7

Phone: 519-669-1501
Toll Free: 1-877-467-3478
www.reistindustries.com